

# Go2 Companion Remote Control

User Manual V1.0

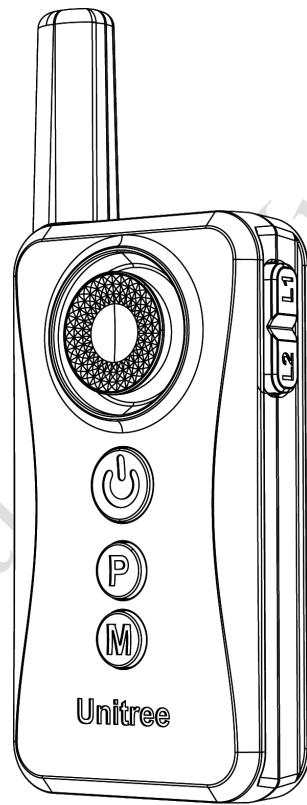

**Unitree**

[www.unitree.com](http://www.unitree.com)

## Introduction

The companion remote control is part of the Go2 remote control module, which can manipulate Go2 to achieve stable and full control of 3-axis posture and 3-axis position when standing. and to achieve forward and backward movements, turning in place, and other actions on flat ground. It can also activate the intelligent accompanying mode with one click, without the need for remote control, and enter the autonomous following state. During the forward process, it can intelligently avoid obstacles based on radar data, ensuring the safety of the robot dog and the surrounding environment. The companion remote control adopts a new buckle design that conforms to ergonomics, making it more secure and comfortable to touch.

## Parts Name

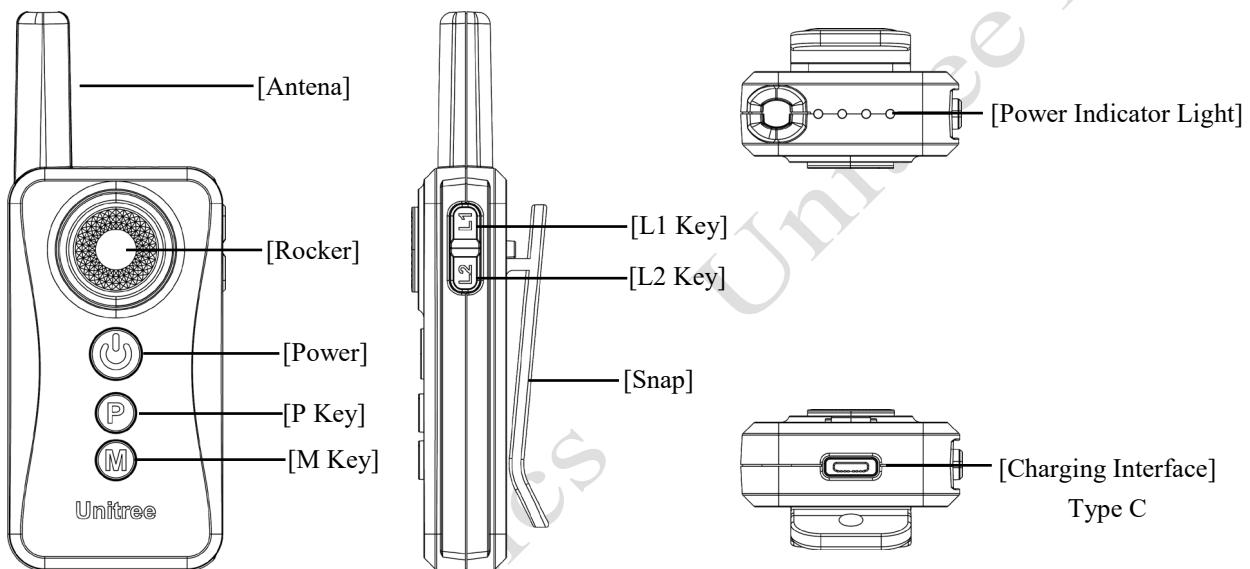

## Technical Specifications

Parameter	Specification	Remarks
Charging Voltage	DC 5.0V	Type-C Interface
Charging Current	600mA	
Lithium Battery Capacity	520mAh	
Standby Current	20uA	
Running Time	About 5h	
Remote Control Distance	Above 15m	Open Environment
Frequency	6240 - 6739.2MHz	6489.6Mhz bandwidth 499.2Mhz
The height of the remote control allowed at any time on the side from the ground	0.2m ~ 1.2m	Wearing between the waist and neck

## Companion Remote Control Turnon/Turnoff

**Turn on/off the companion remote control:** Short press the power button once to turn it on, and then long press for more than 2 seconds to turn it off.

## Companion Remote Control Charging

When the battery indicator light of the companion remote control shows that the battery is low, you should connect the companion remote control to the charger as shown in the figure below:

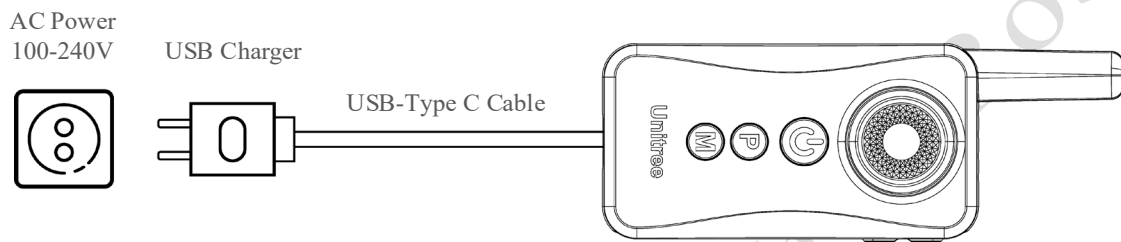

- We recommend you to use a 5V/1A USB charger which meets FCC/CE standard.
- The power indicator light will flash at 1Hz (1 second/time) in charging status and indicate the current power level.
- When the power indicator light is all off it means the battery pack is full, please remove the charger to finish charging.

Charging Indicator Light				
LED1	LED2	LED3	LED4	Current Battery
☀	○	○	○	0%-25%
☀	☀	○	○	25%-50%
☀	☀	☀	○	50%-75%
☀	☀	☀	☀	75%-100%
				Full Charged

## Remote Control Basic Operation

### Key Description

Key	Function	Specific instructions
Power Button	Turn on/off the power supply	a) Short press once to turn on the machine. b) Press and hold for more than 2 seconds to shut down.
P Key	System Reset	a) Short press twice continuously, and the robot dog will cycle between three modes: lying down, damping, and standing up. b) When the robotic dog rolls over, press and hold for 1 second to restore standing.
M Key	Mode Switching	a) Short press once to turn off the companion and enter the joystick control mode. b) Quickly press twice to activate the slow automatic companion mode, with a maximum speed of 1.5m/s. c) In the slow automatic following mode, quickly press twice again to enter the fast automatic following mode, with a maximum speed of 3.0m/s.
L2 Key	Enable/disable automatic obstacle avoidance function	a) Short press twice continuously to activate obstacle avoidance. b) Short press once to turn off obstacle avoidance.
L1 Key	robot dog orientation setting	a) Adjust counterclockwise. Short press the L1 key once (<1s), and the machine dog will default to turning counterclockwise by 0.1rad (approximately 5.7 degrees). b) Adjust clockwise. Press the L1 key twice in a row, and the machine dog will default to facing clockwise at 0.1rad (approximately 5.7 degrees).

### Rocker Description:

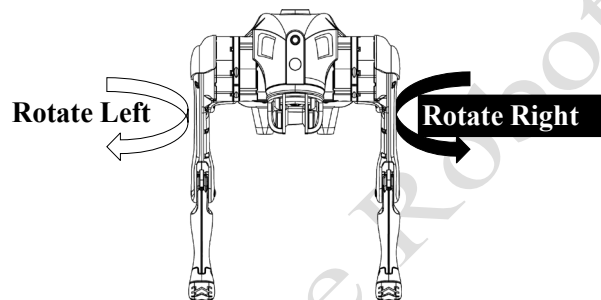
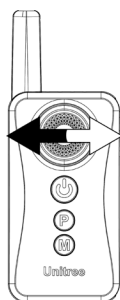
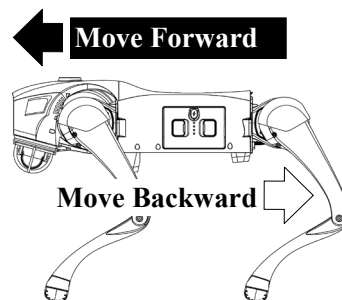
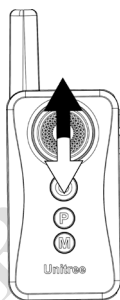

App can not control the robot at the same time with the companion remote control, if you need to use the companion remote control, please do not use the app to control the robot.

**Instructions for use:**

Before powering on Go2, the accompanying remote control should be fixed in the position shown in the figure. After successfully turning on Go2, it will stand up on its own, and the indicator light on the head will remain constant in green. This means that the accompanying remote control can be used to control Go2. The specific operating steps are as follows:

**Step1: Turn on the ISS in the mobile phone App**

- Open Unitree Go App to connect Go2.
- Open the manipulation interface -settings on upper right corner - motion status adjustment - side following.
- Press OFF to turn on the side-following function.

**Step2: Wear and start the companion remote control.**

- Buckle the remote control to the right side of the human body on the belt, stand on the left side of the robot, and keep your torso facing the same direction as the robot.
- Short press the power button of the companion remote control, when the indicator light is on steadily the startup is finished, at this time the remote control is in rocker mode.

**Step3: Start the side-following mode (Important step!)**

- Short press the M button twice to start the slow auto-following mode, the maximum speed at 1.5m/s.
- In slow auto-following mode, short press M button twice to enter fast auto-following mode with maximum speed at 3.0m/s.

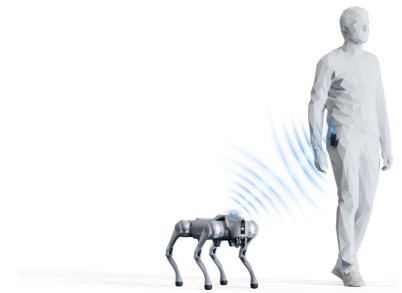
**Step4: Turn on/off obstacle avoidance function**

Short press L2 button twice to turn on the obstacle avoidance; short press once to turn off the obstacle avoidance.

**Step5: Switch off the auto-following function**

- Short press M button once: stop following and enter the rocker control mode.
- Switch on the rocker: Toggle the rocker to stop the follow mode immediately and enter the rocker mode.
- Switch off: Long press the power button of the companion remote control for 2 seconds to switch off.
- Horizontal Placement: Place the companion remote control horizontally.

**Other operating instructions (For adjusting the machine)**

- Rocker control: When the companion remote control enters the rocker mode, the robot movement can be controlled by the rocker. Using the rocker control mode, the remote control can be taken off the belt for control. If you need to continue to use auto-follow after the remote control is taken off, you need to put the remote control on and then turn on the accompaniment.
- Stand up, Down, Damped Mode: Short press 2 times consecutively, the robot switches cyclically between Down, Damped and Stand up modes.
- Side roll: When the robot rolls over on its side, press and hold for 1 second to resume standing.



**Auto following precautions:**

- a) Can not be too fast (less than 1.5m/s in slow mode, less than 3.0m/s in fast mode).
- b) The companion remote control can not be placed too high (within about -10cm~120cm height difference from the robot's head).
- c) When conditions allow, choose a more open route to minimise the triggering of the robot's own autonomous avoidance function.
- d) App can not control the robot at the same time with the companion remote control, if you need to use the companion remote control, please do not use the app to control the robot.
- e) When using, please keep the robot in the line of sight control, with make the robot to maintain a safe distance of at least 2 metres.